



# UAZ PROFI

NEW LIGHT TRUCK



SMARTLY  
PROFES  
SIONAL

# Contents

Variety	p. 4
Convenience	p. 34
Profit	p. 54





# Variety

UAZ Profi light truck	p. 6
Real alternative	p. 8
Versions	p. 10
Basic specifications	p. 12
Exterior	p. 14
Capacity	p. 16
Versatility	p. 26
Opportunities with no end in sight	p. 28
All-Terrain & Off-Road	p. 30
Robust petrol engine	p. 32

# UAZ Profi light truck

A high-performance light truck, as comfortable as a passenger car, combines all the main advantages necessary for your business to thrive. Uncompromisingly.

Cost-efficient and fuel-saving, fail-safe and hard-wearing. The field-proven ZMZ Pro engine goes seamlessly with a 5-speed manual gearbox.

With its body-on-frame design, the UAZ Profi can easily carry 1.5 tons in the city and on rough terrain alike. Without trading off comfort and silence. The only Russian-made light truck equipped with an airbag as a basic trim option.

Consistent performance day after day, however demanding the tasks are. Plenty of choices in everything, whether it be a drive layout, a fuel or cargo bed design. Roomy, yet comfortable and safe.





## Real alternative

Multiple choices is a must. Indeed, the UAZ Profi offers plenty of real alternatives, whatever it is. How many Euro pallets to load: four, five or eight? The vehicle is available with standard or wide bodies, and extended wheelbase.

Single cab is enough or crew cab would be better? Both are available, make your choice. Petrol or natural gas, which one? Either fits. Battling through traffic jams or explore faraway locations off the beaten track? Now that you enjoy choice between RWD and AWD, you may drive up hill and down dale.

# Versions

## Single cab chassis

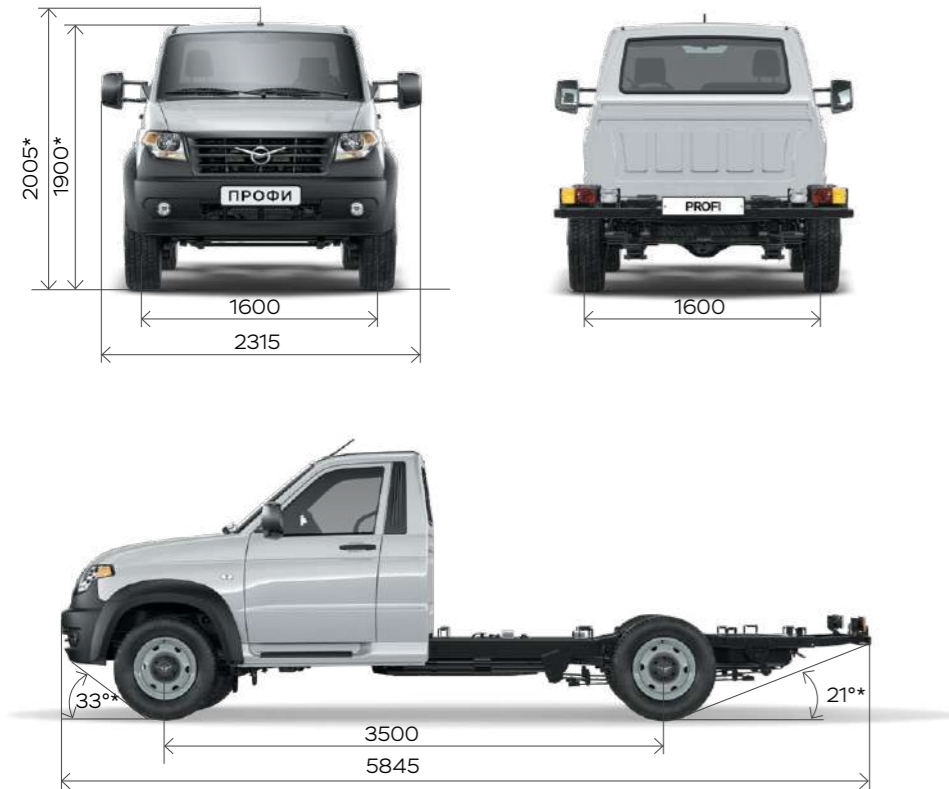

The vehicle dimensions may vary depending on the version.

## Low-sided bed single tires

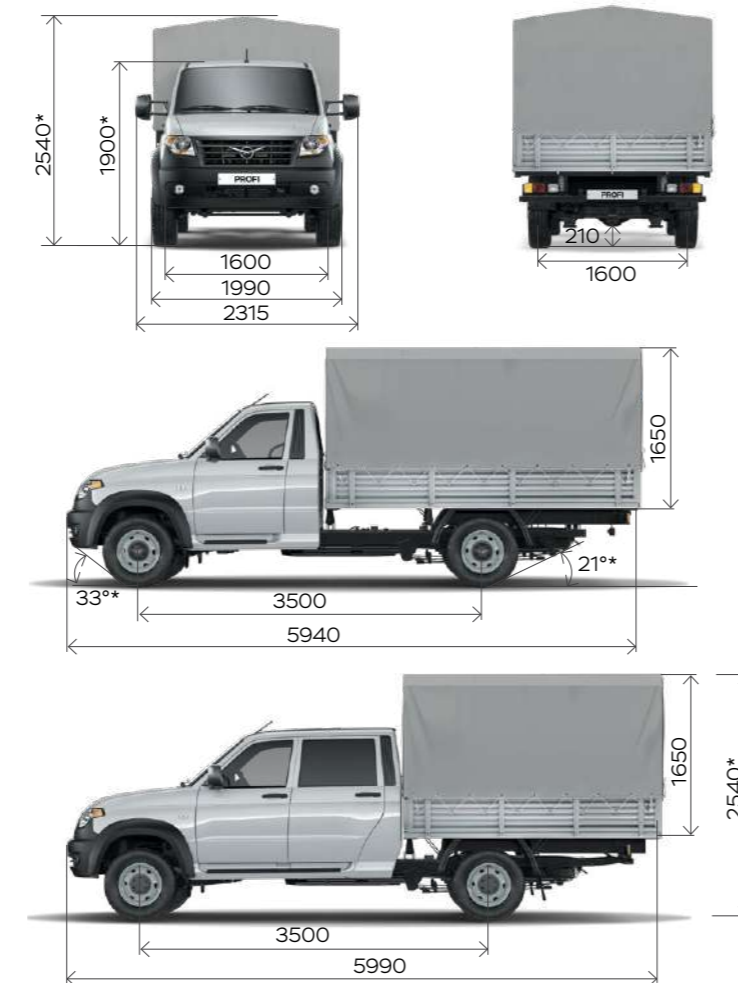

## Low-sided bed dual tires

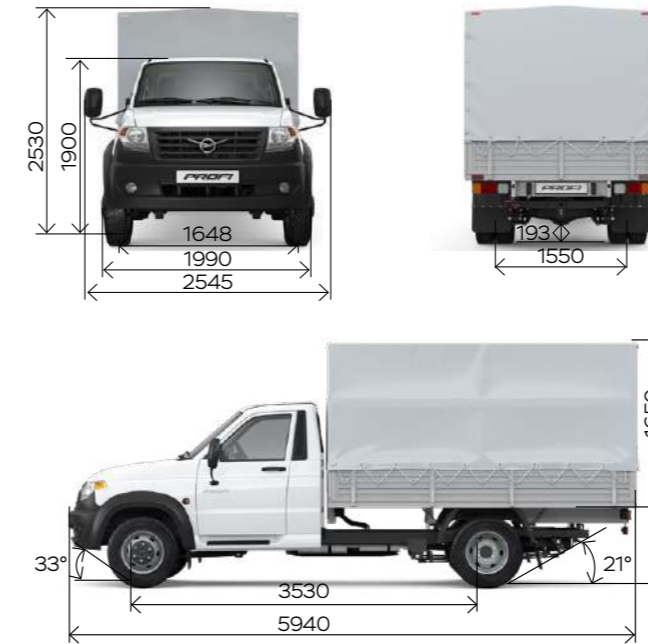

The vehicle dimensions may vary depending on the version.

## Long bed dual tires

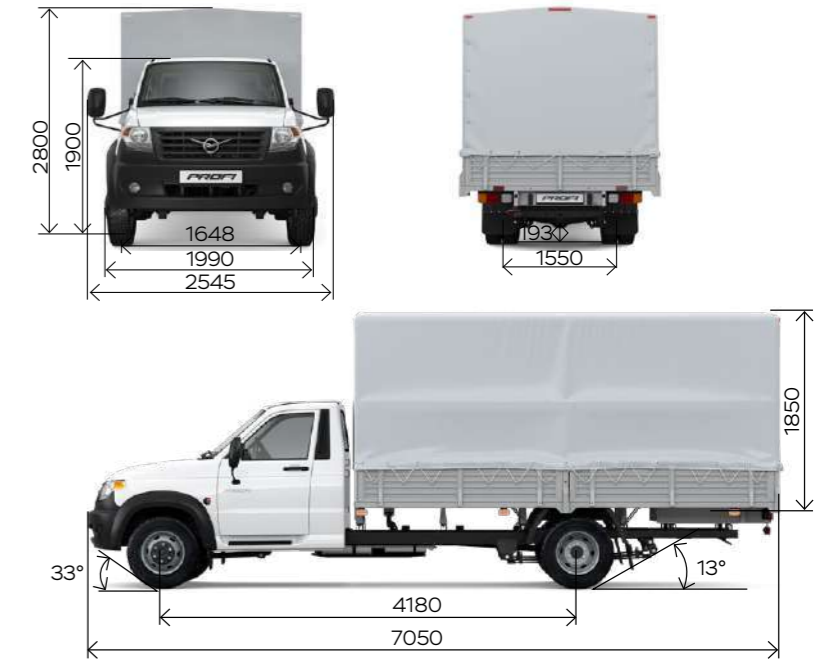

# Basic specifications

Total weight

Drive type

3500 kg | 4×2 | 4×4

Load capacity

Number of seats

1500 kg | 3/2 | 5  
Single cab | Crew cab

Engine

Petrol / Bi-fuel (petrol + gas)



\* Unloading area



# Exterior

Functional style and eye-pleasing look harmonize in brawny image. Elaborated to the last detail, it adds to your success. Unpainted front bumper and fender flares boost your confidence when having to perform evasive maneuvers. Impressive wing mirrors provide a perfect side view. Once you turn the ignition key, the daytime running lights are on. Anti-slip footrests will surely to keep you on your feet.



Radiator grille



Anti-slip footrests



Unpainted front bumper and fender flares



Heated mirrors (for wide bed versions and extra equipment options)



Heated and electrically adjustable mirrors (standard bed versions)



Halogen headlights and daytime running lights



# Capacity

Speaking of Euro pallets... ..or, more precisely, the payload the UAZ Profi can carry. A standard curtain box holds 9.5 cu. m. on four Euro pallets, a wide one holds 10.5 cu. m. on five Euro pallets, and a long one holds 16 cu. m. on eight Euro pallets. Smooth steel boards on the inside, durable plywood flooring and the clear-cut curtain box – together they form a space devoid of protruding parts. Not an inch less! The curtain box as high as 1850 mm allows standing to your full height.

The cargo box on long wheelbase holds 16 cu. m. of freight on eight Euro pallets. And the last but not least, crew cab allows extra 7.2 cu. m. for transportation. Even in the rush hour loading/unloading will be simple thanks to effortlessly opening sides, and you can easily raise the curtain flap by yourself, with no tools used.



Each side of the cargo box opens independently



Translucent panels in the curtain box roof allow for daylight, no extra light needed



# 4x4 Profi sided curtain box options

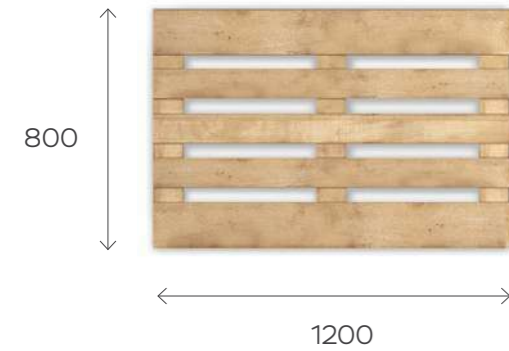

Standard bed



Bed internal dimensions:

3089 × 1870 mm

Capacity:

4 pallets

Sided curtain box capacity:

9.5 cu. m.

Wide bed



Bed internal dimensions:

3089 × 2060 mm

Capacity:

5 pallets

Sided curtain box capacity:

10.5 cu. m.

Crew cab bed



Bed internal dimensions:

2350 × 1870 mm

Capacity:

3 pallets

Sided curtain box capacity:

7.2 cu. m.

# 1.5-ton Profi sided box options

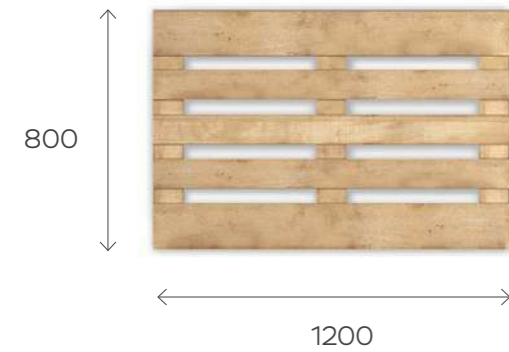

Standard wheelbase



Bed internal dimensions:

3089 × 2060 mm

Capacity:

5 pallets

Sided curtain box capacity:

10.5 cu. m.

Long wheelbase



Bed internal dimensions:

4200 × 2060 mm

Capacity:

8 pallets

Sided curtain box capacity:

16 cu. m.

# “Standard” cargo box

wheelbase 3500/3530 mm



CAPACITY UP TO  
**11.62**  
CU. M.

## Consumer goods

Internal dimensions of the box

3035 × 2075 × 1845 mm

Box capacity

11.62 cu. m.

## Refrigerator

Internal dimensions of the box, Class A / Class C\*\*

2985 × 2050 × 1770 mm  
2935 × 1995 × 1750 mm

Box capacity, Class A / Class C

10.83 / 10.25 cu. m.

## Refrigerator

Internal dimensions of the box

2935 × 1995 × 1750 mm

Box capacity

10.25 cu. m.

# “Optimum” cargo box

wheelbase 3500/3530 mm



CAPACITY UP TO  
**11.47**  
CU. M.

## Consumer goods

Internal dimensions of the box

3005 × 2050 × 1860 mm

Box capacity

11.46 cu. m.

## Refrigerator

Internal dimensions of the box, Class A / Class C

3010 × 2060 × 1850 mm  
2910 × 2020 × 1780 mm

Box capacity, Class A / Class C

11.47 / 10.46 cu. m.

## Refrigerator

Internal dimensions of the box

2910 × 2020 × 1780 mm

Box capacity

10.46 cu. m.

\* The appearance of the cargo boxes may differ depending on the intended purpose. Dimensions are for reference only and may vary depending on modification.

\*\*Class A / Class C refer to storage temperatures between +12°C and 0°C / +12°C and -20°C

## “Standard” cargo box

wheelbase 4180 mm

CAPACITY UP TO  
**15.42**  
CU. M.



### Consumer goods

Internal dimensions of the box

4035 × 2075 × 1845 mm

Box capacity

15.45 cu. m.

### Refrigerator

Internal dimensions of the box, Class A / Class C\*\*

4085 × 2050 × 1770 mm

Box capacity, Class A / Class C

14.82 cu. m.

\* The appearance of the cargo boxes may differ depending on the intended purpose. The vehicle dimensions may vary depending on the version.  
\*\* Class C boxes keep storage temperature between +12°C and 0°C only All dimensions are in millimeters.

## “Optimum” cargo box

wheelbase 4180 mm

CAPACITY UP TO  
**15.65**  
CU. M.



### Consumer goods

Internal dimensions of the box

4105 × 2050 × 1860 mm

Box capacity

15.65 cu. m.



## Versatility

What professionals do appreciate is versatility, which is a prerequisite for rewarding multi-purpose performance. That's when UAZ Profi comes handy. Our truck keeps evolving to keep pace with exceedingly growing and everchanging demands and destinations. Whether on city streets, on international highways or even on rough terrain – it rises to challenges.

Even RWD versions of the UAZ Profi are strikingly powerful on the rough terrain thanks to a ground clearance of 193 mm and state-of-the-art geometry for superior cross-country capabilities. While boasting perfect road-holding on smooth surfaces too. Dual wheels on the rear axle, steering damper and extended front track remarkably enhance stability and overall performance.



# Opportunities with no end in sight

## City

The RWD version of UAZ Profi is designed for easy transportation in the urban environment. Open-type steering knuckles ensure car-like maneuverability even in cramped and confined spaces. With the lofty driving position offering the outlook of the traffic on busy streets, the trucker is the master of situation.

## Highway

Beyond the city limits, the powerful and torquey ZMZ Pro engine will show its best. Its unceasing stamina will give you peace of mind. Long trips across Russia are fraught with risks due to the vagaries of the weather. A seemingly safe road, dry and inviting, turns into a slippery trap in no time. The UAZ Profi has everything to keep you safe in challenging conditions. Even the basic trim comes with ABS.



## Dirt road

As long as you are driving along a highway, there is no point in employing all-wheel drive. However, trucks that never entered dirty roads are few and far between. Such trips will not be an ordeal any longer, as the rigid rear axle locking differential will help you out, even on RWD versions of the UAZ Profi. High ground clearance further ensures that you reach the destination as scheduled.

## Cross-country

See the road? No? There is one, though! Now that the UAZ Profi is perfectly equipped for cross-country and rough terrain conditions – all-wheel drive, a low-range gearing and a controlled rear axle locking differential – the road has no end in sight.

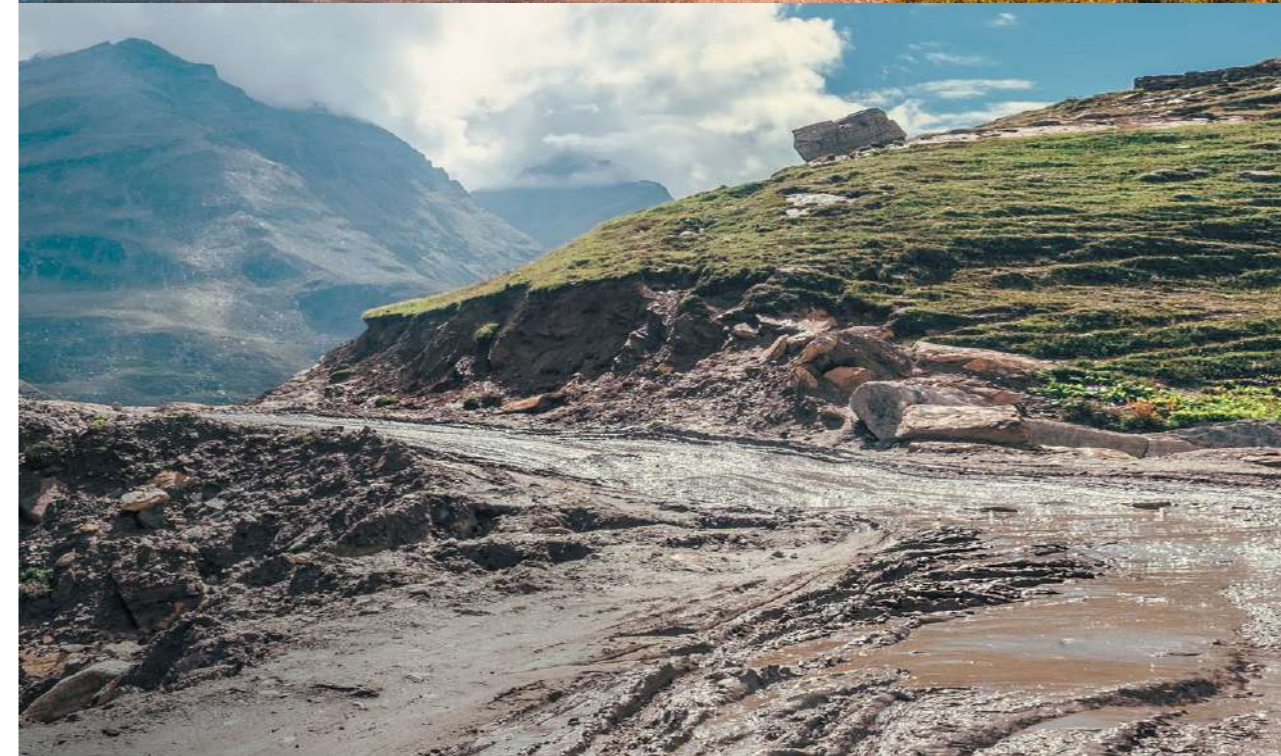

# All-Terrain & Off-Road

Ain't no road too rough any longer. Never mind the road surface - compliments to broad ground clearance and optional rear axle locking differential, manually activated with a button in the cab and automatically deactivated at a speed of 30 km/h. Don't let one wheel stop while the other is skidding.

Should these tricks be inadequate on the worst impassable spots, all-wheel drive with low-range gearing will be your saving remedy.

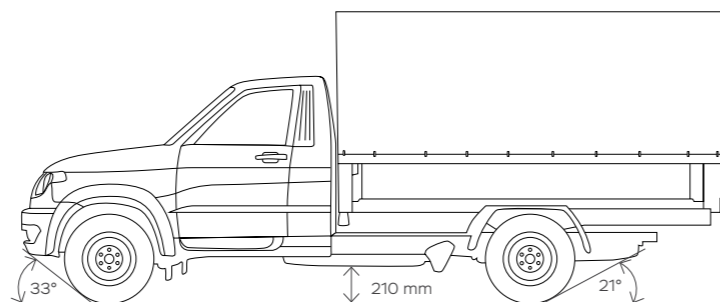

33°

Angle of arrival

21°

Angle of departure

210 mm

Ground clearance (\*4x4)



\* optional for all UAZ Profi versions

EATON rear axle locking differential

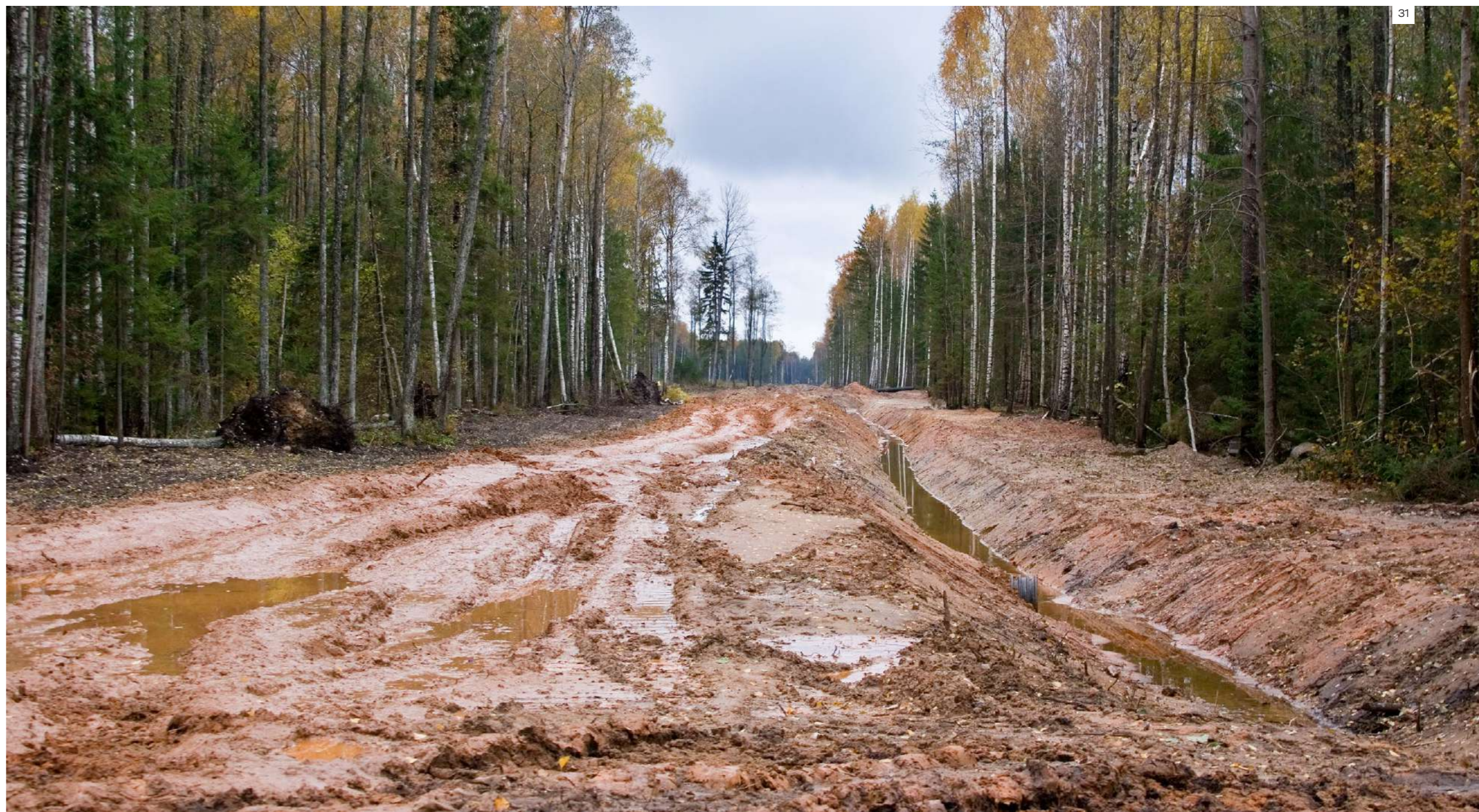



# Robust petrol engine



**ZMZ PRO**  
**149.6<sub>hp</sub>**  
**ENGINE**

Power – thrust – fuel consumption. The three vital engine parameters. What does it take to balance them out perfectly? The ZMZ Pro engine is designed to puzzle it out. Its nearly 150 horses will keep your vehicle up and running at full throttle. The ZMZ Pro produces 235.4 Nm of torque, with maximum thrust delivered at rpm as low as 2650.

Our most thrifty customers may take the advantage to opt for an LPG-compatible engine at once and order it ex-works. No extra registration required. Manufacturer's warranty remains valid.

Troubleshooting? No, thanks: we opt for trouble-free solutions. Such as a flexible-fuel engine, or globally rugged parts, from the cylinder head to the timing chain. Many make promises, but we are so confident of our quality that we offer a 4 year or 200,000 km warranty on the ZMZ Pro engine.

The updated engine delivers increased torque at low revs.

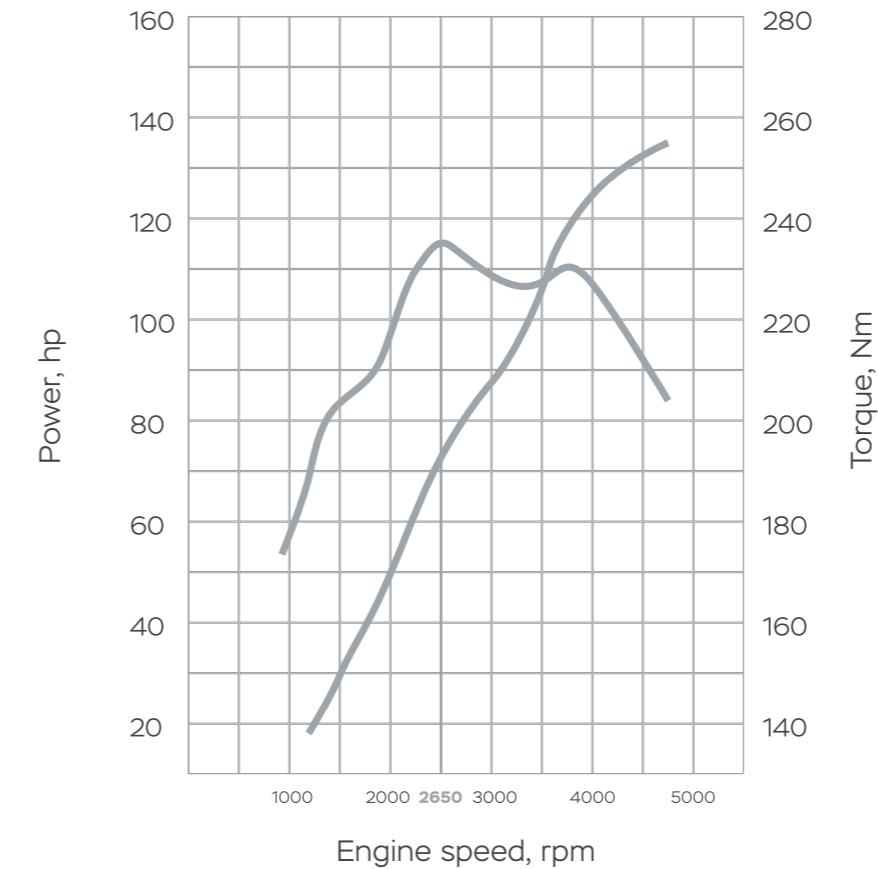

## Ultimate advantages and benefits all around: LPG kits ex-works

Certified, factory-installed LPG (propane-butane) kits

- Gas conversion kits
- Type of fuel used: petrol / LPG (Liquified Petroleum Gas)
- liquefied gas (propane-butane)
- Gas cylinder capacity 93/100/150 l
- Manufacturer's warranty remains valid
- Quick payback for LPG kits
- Total cruising range exceeds 1000 km

**4 YEARS WARRANTY**  
 or  
**200,000 KM**

**TORQUE**  
**235.4<sub>Nm</sub>**  
 @ 2650 rpm.

**Original LPG kits**  
 from the manufacturer



# Convenience

Interior	p. 36
Safety	p. 38
Features	p. 40
Usability and comfort	p. 42
Climate control system	p. 44
Steering response	p. 46
Customizing for freighting	p. 48
Cargo bed equipment	p. 50
Curtain box equipment	p. 52

# Interior



Interior view of the UAZ Profi, 4x2 version



Interior view of the UAZ Profi, 4x4 version



# Safety

You may surely feel safe and sound when driving your UAZ Profi. Rather than other designs, conventional cab is more than about keeping your head. Quite often it's about saving your life. We have considered all possible risks and did our utmost to secure your safety all around, from daytime running lights to wide heated mirrors. An alarm system including immobilizer to safeguard your vehicle and freight.

When the going gets tough, the vital ABS and EBD systems may be a heaven-sent rescue. And the last line of defense is the three-zone collapsible steering column and airbag.



The conventional cab has proven to be the safest in head-on collisions



EBD – Electronic Brake Distribution

Driver airbag



Height-adjustable seat belts

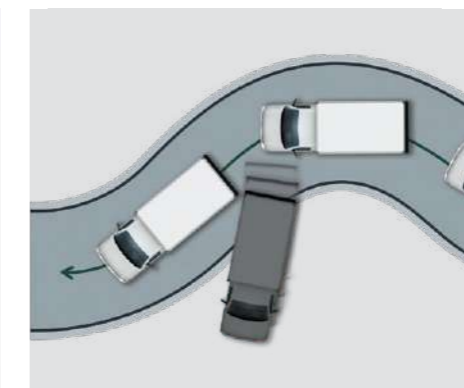

ABS – Anti-lock braking system



Terminal of ERA-GLONASS emergency system

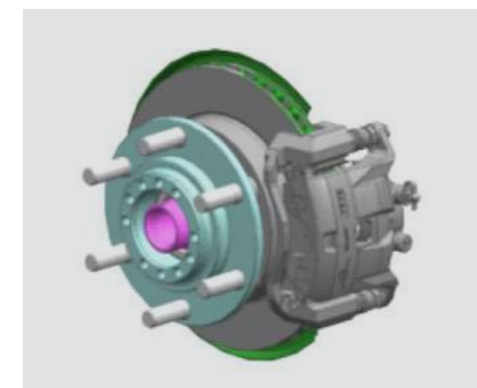

Front and rear vented disk brakes (for 4x2 versions)

# Features

## Storage compartments



Overhead console (single cab)

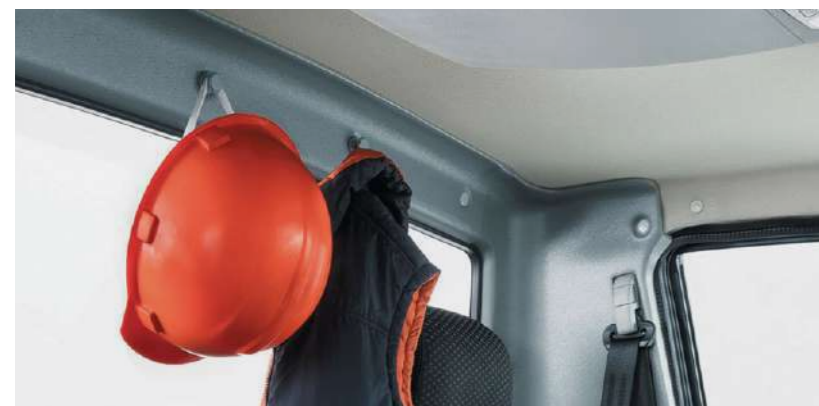

Clothes hooks (single cab)



Two glove boxes



Map pockets in the doors, upper and lower glove boxes, spacious storage box within armrest console (for the 4x4 version)

# Usability and comfort



The steering wheel can be adjusted for height and for depth

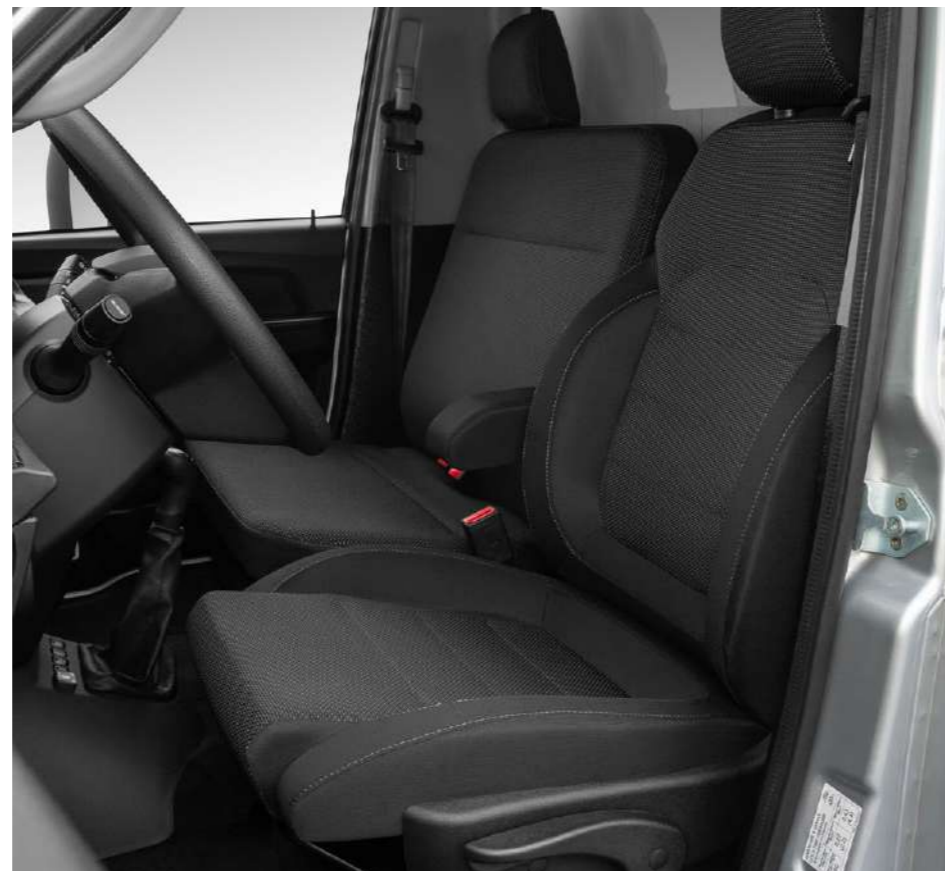

New comfortable bucket seat with advanced lateral support, extended cushion, heating, height adjustment and lumbar support (in the Comfort package)



Handrails on pillars



Cruise control

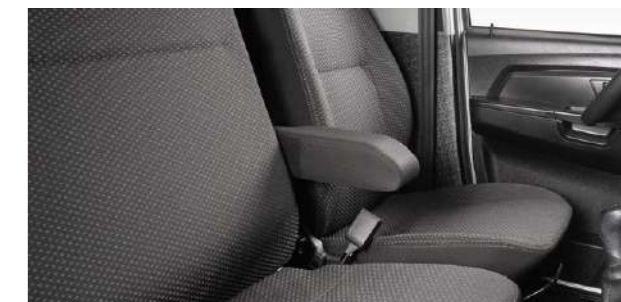

Armrest (for 3-seater)



Trendy steering column stalk switches and light control unit



On-board computer operated via the left steering column switch



Right steering column switch with adjustable windscreen wiper delay



Power windows and wing mirrors controls on the driver's door



A 12V socket, a niche for sundries and easy-to-reach climate control module



Tool organizer (for 3-seater)

# Climate control system

Winterization



Heated rear-view mirrors.  
Heated windshield, heated seats are available in the Comfort package.

Hot weather? Climate control, no sweat



The air conditioner comes complete with a chilled glove box in the Comfort package.  
The basic trim comes with A/C cab filter.



# Steering response

## Front suspension

The upgraded front suspension of the 4x2 version with four trailing arms and a straight, stiffer Panhard rod allows keeping the caster angle while driving. Steering system with separately fixed high-rigidity direct linkages and a damper enhance steering response and cornering ability of the LCV. Taken together, these innovations add to steering response and driving characteristics of the UAZ Profi, which takes the driving experience to the level of a passenger car.

The 4x4 Profi version comes with dependent spiral-spring suspension and anti-roll bar ensures smooth running regardless of road surface. The high energy absorption capacity of the suspension ensures smooth running even on rough surfaces, while offering the same reliability as leaf-spring suspensions. The UAZ Profi design employs the steering knuckles to enhance maneuverability and reduce the turning circle. Besides, the suspension design is designed so as to prevent so-called 'nosediving', which makes even sudden braking comfortable.





## Customizing for freighting



Thanks to its robust frame structure, the UAZ Profi shows great class when performing the most arduous tasks on notorious Russian roads and provides for the most diverse extra equipment to be installed. The model is equipped with six-lug hubcaps and special heavy-duty tires for commercial vehicles. Each tire withstands the most intense loads thanks to its wide-base profile and reinforced with extra plies as required for trucks. The new 1.5-ton Profi version has a frame of two rigidly welded 140-mm high 3.5-mm thick U-shaped sections.

Extra cross members and reinforcements were installed to further protect the critical areas. In addition, changes were made to the suspension attachment elements, including the stabilizer with links and shock absorbers. Thanks to increased camber and 50 mm wider track, new leaf springs in the 4x2 version level out UAZ Profi position when it's fully loaded. Together with dual wheels and 195/75R16 tires on the rear axle, they ensure a load capacity margin, enhance road-holding, reduce lurching when cornering and reduce axle load.

# Cargo bed equipment



Translucent roof Robust weatherproof curtain box



Durable plywood flooring, with flush lashing points to secure freight



Footrest and secure tailgate fixation



Rear lights indicating the vehicle dimensions with its tailgate open



Lockable box under the cargo bed



Rear position lamps (wide bed)



By pulling the straps, you can easily raise the curtain flap by yourself, with no tools used, and fix it open up with hooks

# “Standard” curtain box equipment



Lighting and signaling system (rear view)



Fittings



Sill plate



Handrail



Interior light



Hinged rear doors

\* the appearance of the cargo boxes may differ depending on the intended purpose

# “Optimum” curtain box equipment



Lighting and signaling system (front view)



Fittings



Sill plate



Handrail



Interior light



Hinged rear doors

\* the appearance of the cargo boxes may differ depending on the intended purpose



# Profit

Certified LPG (propane-butane) kits ex-works	p. 56
Aerodynamic spoiler	p. 58
Special financial services for UAZ Profi buyers	p. 60
UAZ subscription	p. 62
Best warranty and cost of ownership	p. 64
Budget-friendly maintenance and service plans	p. 66
Available colors	p. 68
Specifications	p. 70

# Certified LPG (propane-butane) kits ex-works

- Italian-made G4 gas conversion kits by Lovato
- installed during manufacturing
- manufacturer's warranty remains valid
- quick payback
- fuel savings up to 20% \*
- gas cylinder capacity - 93/100/150 l \*\*
- total cruising range exceeds 1 000 km



GAS  
CYLINDER  
**150**  
LITERS

CRUISING  
RANGE  
EXCEEDS  
**1000**  
KM

\* proven during tests for fully-loaded vehicles running in certain driving modes at a constant speed

\*\* 93 l for the low-sided version; 100 l for the wide cargo bed version, 4x2 and 4x4 sided curtain box version; 150 l for vehicles with 4180-mm wheelbase.

## Aerodynamic spoiler

While notably reducing fuel consumption, the roof spoiler boosts road-holding. The spoiler is installed by fixing on dedicated spots thus leaving the cab paintwork intact.



Top caption: Warehouse for home and business, bottom caption: Unloading area

# Special financial services for UAZ Profi buyers

## UAZ Finance

Clearly calculated. Our special offers spell out why the UAZ Profi is a real bargain worth buying. We offer the minimum down payment and interest rate, with monthly installments of a balloon loan by far smaller than standard programs.

Keep calculating. Cost-conscious businesses will surely appreciate leasing at a reasonable price and big discounts.

UAZ Leasing plans offer ample opportunities for savings and benefits.

\* The given data are preliminary and may vary depending on specific conditions

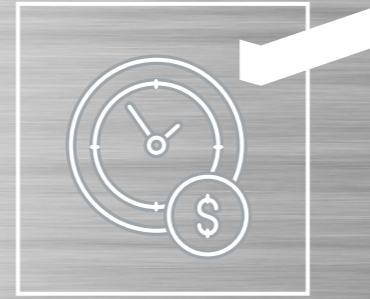

### UAZ Credit

For those scrupulous about financial discipline and value their time

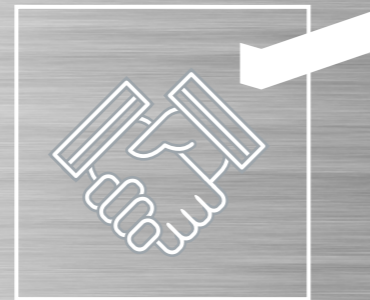

### UAZ Leasing

If you are a business owner pondering a lease purchase, you are definitely interested in optimizing the costs of purchase, maintenance and fleet renewal.

01

Payment in arrears

02

Minimum monthly installments

03

Reduced insurance rate

01

Trade-in Plan

02

Recycling Plan

# UAZ subscription

UAZ Subscription offers a long-term lease including services in fixed installments without a down payment.



## VEHICLE

Purchasing  
Motor vehicle tax  
Vehicle registration



## SERVICES

Scheduled and urgent maintenance  
  
24/7 roadside assistance and vehicle recovery



## INSURANCE

Insurance plans (up to 1.5 m RUB)  
  
Comprehensive Cover – direct contracts, unlimited driver headcount



## TIRE-FITTING SERVICES

Purchase, seasonal swapping, storage and disposal of tires (optional)



## TELEMATICS

Vehicle monitoring, including mobile app for drivers, web portal for fleet management





01

Basic warranty

4 years /  
150,000 km  
warranty

02

ZMZ PRO  
engine warranty

4 years /  
200,000 km  
warranty

03

Corrosion  
perforation  
warranty

6 years / 150,000 km  
warranty

Best warranty and  
cost of ownership

Time is money. Save on both. UAZ offers an unrivalled warranty for the new truck: 4 years or 150,000 km of mileage. Unbeatable offer that no-one can outbid. A Profi ownership is even more attractive with affordable parts, budget-friendly maintenance and customer-centered service.

# Budget-friendly maintenance and service plans

## After-sales service contract

This is a real bargain as it covers a package of services for the maintenance of your UAZ vehicle fleet, sold at a fixed price, which is always less than the cost of separate maintenance checks.

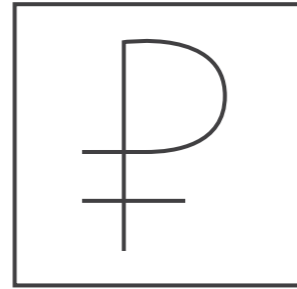

Predictable and transparent cost of ownership

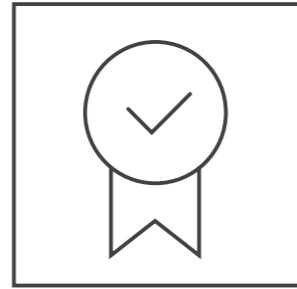

Quality of an authorized dealer's services

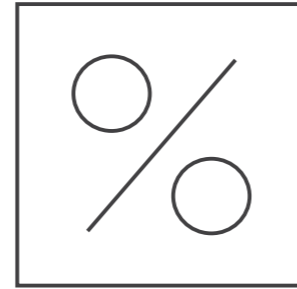

Save up to 15% on our service plans

## Terms and conditions of the after-sales service contract

01

Our customers are encouraged to purchase one of 4 programs at their discretion, valid for 1 to 4 years. Beside routine maintenance as advised by the manufacturer, the customers may wish to add optional service package including replacement of parts prone to wear and tear.

02

The UAZ PROFi service contract can be purchased either when signing a contract for a new vehicle supply or prior to the first maintenance check.

# Extra benefits

## “Top Priority”

Urgent and priority maintenance services in the event of a breakdown. High quality at a competitive price.

## Cost planning

The fixed price of services facilitates cost-planning during corporate budgeting.

## Expertise in maintenance

Extends the service life of the vehicle fleet and keeps the manufacturer's warranty valid.

## Minimal downtime

Thanks to prompt maintenance.

## Affordable spare parts: cheaper than outsourced equivalents

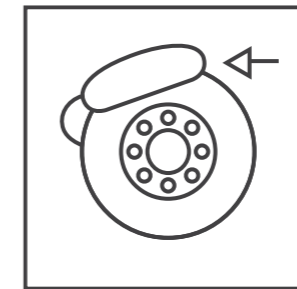

Replacement of brake shoes

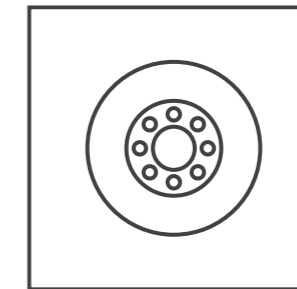

Replacement of brake discs (4x2) and rear brake drums (4x4)

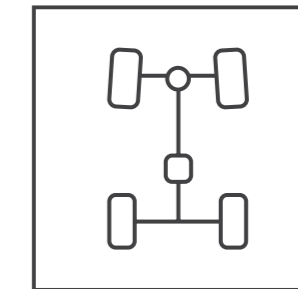

Front wheel alignment, adjustment

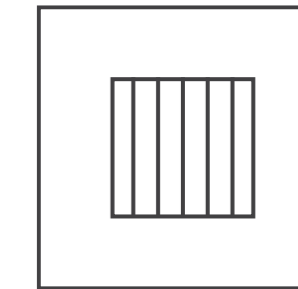

A/C cab filter replacement

# Available colors



Matt white

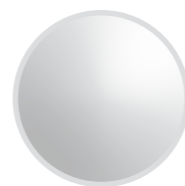

Matt grey

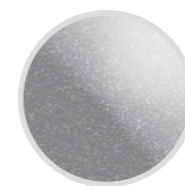

Metallic silver

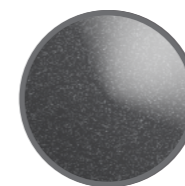

Metallic charcoal

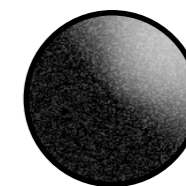

Metallic black

	UAZ Profi			
Model	236022	236031	236031	236324
Drive	4x4	4x2	4x2	4x4
Cab	Single	Single	Single	Crew
Wheelbase	Standard	Standard	Long	Standard
Passenger capacity (seats)	2	3	3	5
Weight and dimensions				
Unladen weight, kg	2065	2085	2290	2225
Total weight, kg	3500	3500	3500	3500
Load capacity incl. passengers, kg	1435	1415	1210	1275
Max front axle load, kg	1230	1125	1225	1200
Max rear axle load, kg	2270	2375	2275	2300
Overall length, mm	5940		7050	5990
Overall width, mm	1990 / 2315 (mirrors folded), 2545 (mirrors unfolded)			
Overall height (cab), mm	1900			
Overall height (incl. curtain box), mm	2540	2530	2800	2540
Wheelbase, mm	3500	3530	4180	3500
Front track width, mm	1600	1648	1648	1600
Rear track width, mm	1600	1550	1550	1600
Turning circle, m	6.9	6.1	7.1	6.9
Front overhang, mm	850	820	820	820
Rear overhang, mm	1590	1590	2050	1640
Angle of arrival / departure, degrees	33/21	33/21	33/13	1640
Min. ground clearance, mm	210	193	193	210
Cargo bed	Single cab			Crew cab
External dimensions, LxW, mm	3200X1990 (2180)	3200X2180	4315X2180	2460X1990
Internal dimensions, LxW, mm	3089X1870 (2060)	3089X2060	4200X2060	2350X1870
Bed area, sq. m.	5.8 (6.4 on wide bed)	6.4	8.65	4.4
Capacity in pallets, pcs.	4 (5 on wide bed)	5	8	3
Bed capacity, incl. curtain box, cu. m.	9.5 (10.5 on wide bed)	10.5	16.0	7.2
Loading height, mm	986	966	957	986

Engine	Petrol	Bi-fuel
Model	ZMZ-409051	ZMZ-409052
Cylinder arrangement	4 in-line	4 in-line
Actual displacement, cc	2693	2693
Engine bore and stroke, mm	95.5 X 94	95.5 X 94
Max. power, kW (hp) @ rpm	110 (149.6) / 5000±100	105.15 (143) / 5000±100*
Max torque, Nm @ rpm	235.4/ 2650±100	227.5/ 2650±100*
Fuel to use	Regular (92 RON) / Premium (95 RON)	Regular (92 RON) / Premium (95 RON) / propane-butane for vehicles
General specifications		
Fuel tank and gas cylinder volume, l	68	68 (petrol) 93 (propane-butane) 100 (propane-butane), box body
Constant-speed fuel consumption (80 km/h), l**	11.6	13.8
Max speed, km/h	130	125
Transmission	for 4x2	for 4x4
Drive type	rear-wheel	on-demand AWD
Gearbox	5-speed manual gearbox	
Transfer case		Transfer case with high and low-range gearing (gear ratio 1.94)
Chassis		
Front suspension	dependent, spiral-spring, with anti-roll bar	
Rear suspension	dependent, leaf-spring, with anti-roll bar	
Steering system	Hydraulic power assisted steering system	
Brake system	Hydraulic brakes with ABS, plus vacuum booster	
Service brake type (front axle / rear axle)	Ventilated disk brakes	Ventilated disk brakes /
Drum brakes	5,5Jx16H2	6.5Jx16H2
Hubcaps	5.5Jx16H2	6.5Jx16H2
Tires	195/75R16C	225/75R16C
Load index	Min. 103 (875 kg)	Min. 117 (1285 kg)
Tire speed rating	N (140 km/h)	N (140 km/h)



For the purchase and maintenance of UAZ vehicles, please contact the authorized dealers in your region. The contents of this booklet are for promotional purposes only. Exterior and interior colors shown in this booklet may differ slightly from actual colors due to color restrictions in printing. The images may show accessories and extra options unavailable in the basic trim of the vehicle. Some equipment may differ depending on the market. The company reserves the right to make changes to the specifications and packages indicated in this booklet without prior notice.